

NOTE: This is an installation *supplement*. Please refer to the original IOM for all applicable products before using this document.



APPLICATION:

Generic steel mullions can be used to separate vertically mounted galvanized steel fire dampers in wall openings larger than the UL permitted multiple damper assembly size. Mullions can either be used vertically, horizontally or both to split up a vertical wall opening requiring use of a damper having a 1-1/2 hour fire resistance rating. Maximum mullion span is 120" plus expansion allowance when used either horizontally or vertically.

INSTALLATION GUIDELINES

1. The opening must not exceed 120" (3048mm) high, but can be any width provided a vertical support mullion is used a maximum of every 120" (3048mm).
2. To properly use support mullions they must be fabricated and installed according to these instructions.
3. This generic support mullion is permitted by UL to only be used in static systems. A static system is one in which the fan shuts down in the event of a fire or smoke alarm.
4. Sleeves are to be around each damper assembly. Mullions are not intended to be in the airstream, (i.e. exposed to flow) or to be a part of the ductwork.
5. Steel mullions are intended for use in a concrete block or solid concrete wall. Hollow concrete blocks are to be filled with concrete (minimum 3500 psi) to permit proper mullion anchoring.
6. Wall thickness is to be 7" (178mm) minimum, 12" (305mm) maximum.

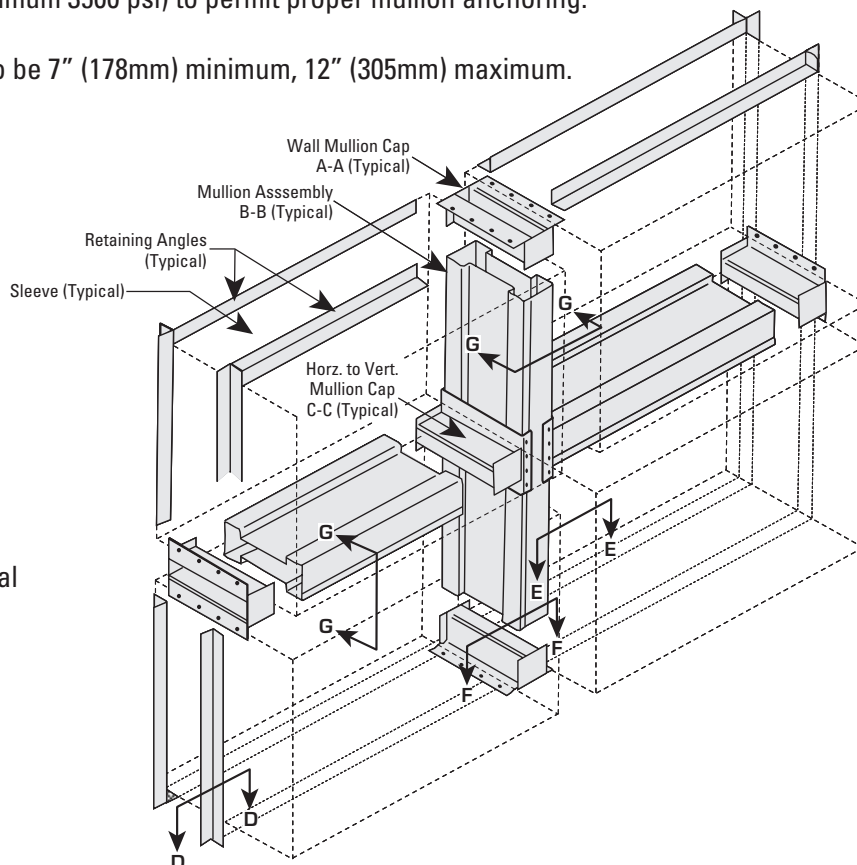

NOTE:

Support mullions can only be used with static systems, vertical walls and 1-1/2 hour rated fire dampers.

FABRICATION OF MULLIONS:

Support mullion assemblies consist of three basic parts:

1. Wall mullion cap
2. Horizontal to vertical mullion cap
3. Mullion sections

Determine the number of each piece required to complete the installation.

FABRICATION OF WALL MULLION CAPS:

SEE DETAIL A-A. Wall mullion caps must be constructed from 12 ga. steel with a minimum yield strength of 42,000 psi.

1. Fabricate the formed section as shown in Detail A-A.
2. Shear the cap end plate to required dimensions.
3. Weld the cap end plates to the formed section with 1/8" (3mm) fillet welds completely around the top edges of the formed section.
4. Drill and countersink 8 holes (4 on each side for 1/4-20 flat head machine screws).

FABRICATION OF MULLION SECTIONS:

SEE DETAIL B-B. Mullions must be constructed from 16 ga. steel with a minimum yield strength of 42,000 psi.

Important: The "D" dimension shown has been calculated to include the necessary clearances required for thermal expansion in the mullions. The values can be found using Table 1 on this page.

1. Form two identical pieces of mullion section as shown in Detail B-B.
2. Connect the two mullion sections together. Use 3/16" (5mm) steel blind rivets or 3/4" (19mm) long intermittent welds 12" (305mm) on center and a 6" (152mm) maximum from both ends.

Important: Both sides of the mullion piece should be fastened using the method described above.

Opening Width/Height	D	H
12	11-1/2"	3-1/2"
24	23-1/2"	3-3/8"
36	33-3/8"	3-1/2"
48	47-1/4"	3-5/8"
60	59-1/8"	3-3/4"
72	71"	3-7/8"
84	82-7/8"	4"
96	94-3/4"	4-1/8"
108	106-3/4"	4-1/4"
120	118-3/4"	4-3/8"

$E = \text{Wall Thickness} - 1/2"$ • $F = \text{Wall Thickness} + 1/4"$

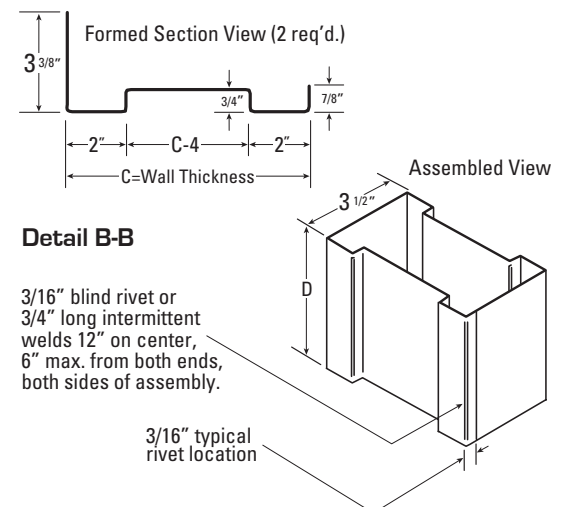
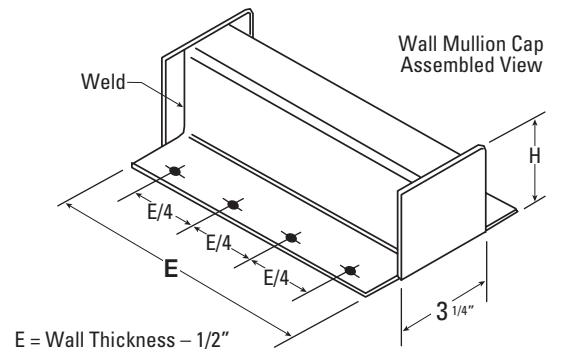
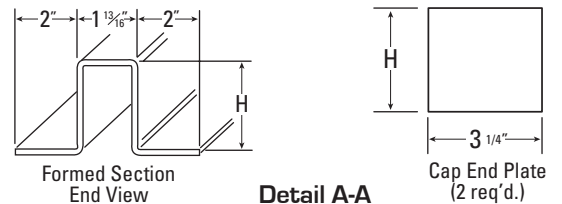

FABRICATION OF HORIZONTAL TO VERTICAL MULLION CAPS (DETAIL C-C):

Horizontal to vertical mullion caps must be constructed from 12 ga. steel with a minimum yield strength of 42,000 psi.

Important: The H, E and F dimensions shown have been calculated to provide the correct performance. The values can be found by using Table 1 on page 2 of this document.

1. Form the horizontal mullion channel as shown in Detail C-C.
2. Drill 12, 3/16" (5mm) dia. holes into the horizontal mullion channel using the dimensions shown.
3. Form the center channel as shown.
NOTE: If the center channel is to be made from two pieces, weld them together with an 1/8" (3mm) fillet weld.
4. Shear the end plates to the dimensions required.
5. Weld the end plates to the center channel with 1/8" (3mm) fillet welds completely around the top edges of the center section.

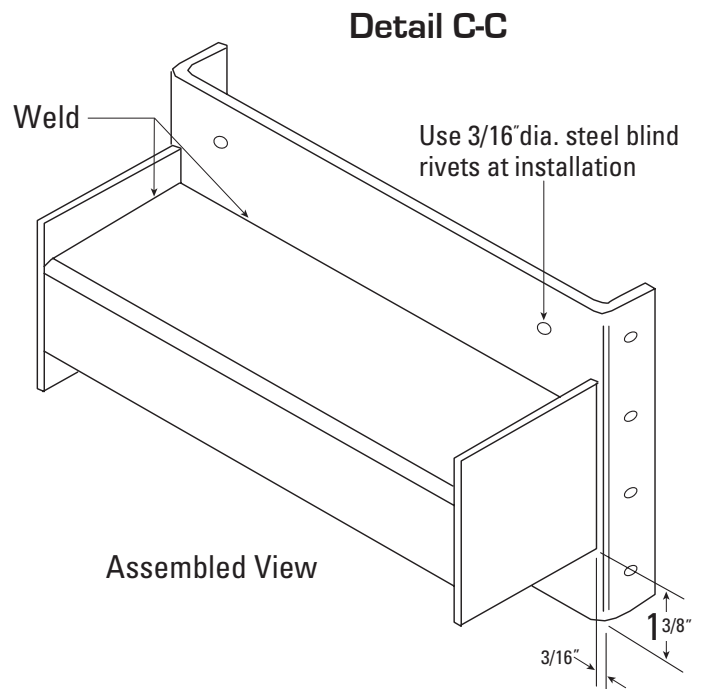
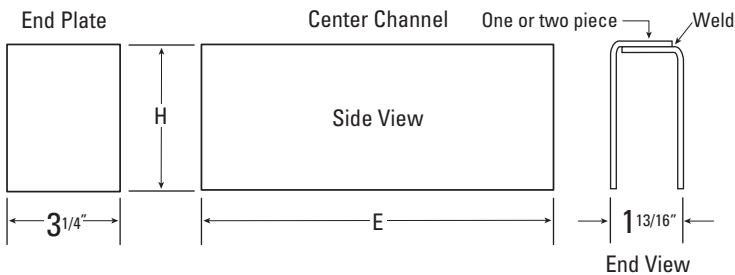
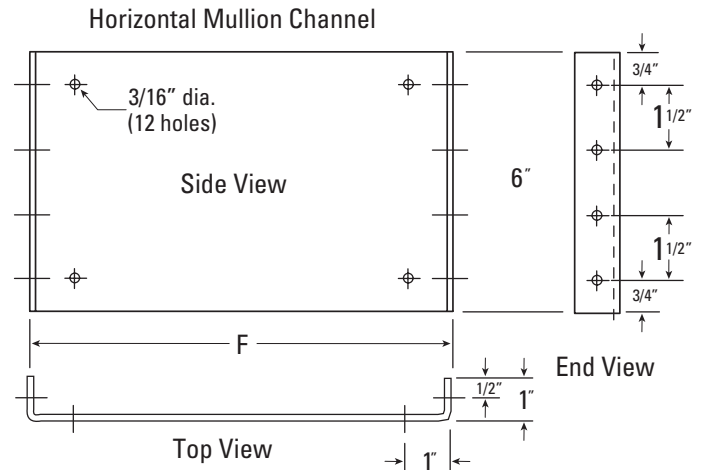

MULLION INSTALLATION (FIGURE 1):

Before the fire dampers are installed into the wall the mullions must first be anchored into the wall. The fire dampers may then be installed into the mullion assembly. To correctly attach the mullions to the wall follow these steps:

1. Anchor wall mullion caps to wall using 1/4-20 x 5/16" (8mm) long flat head steel bolts and 3/8" (10mm) diameter by 1" (25mm) long concrete expansion anchors. If steel lintels are present, use two 1" (25mm) long welds on each side of mullion caps.
Note: End caps must be inserted into the ends of the mullions before they are anchored to the wall.
2. Anchor horizontal mullion caps to vertical mullion caps with 3/16" (5mm) diameter steel blind rivets in 12 places.
Note: Mullion caps must be inserted into the ends of the mullions before they are anchored to the vertical mullions or wall.

FIRE DAMPER INSTALLATION:

Galvanized steel fire dampers must be UL classified for 1-1/2 hour fire resistance. They must be installed in galvanized steel sleeves and be retained by minimum 1-1/2" x 1-1/2" (38x38), 16 ga. retaining angles on each side of the wall, (see Detail D-D).

Retaining angles must overlap mullions or wall by 1" (25mm) minimum (see Detail E-E). Fasten to sleeve using 1/4" (6mm) dia. bolts, 3/16" (5mm) steel rivets, welding, or #10 sheet metal screws.

All must be attached 6" (152mm) on centers, 2" (51mm) maximum from corners. Do not fasten retaining angles to the wall or mullions. Mullions must be free to float (see Detail G-G).

Total expansion clearance between sleeve and wall/mullion of 1/8" (3mm) per foot of wall opening or mullion span should be allowed. Maximum clearance is 1-1/4" (32mm).

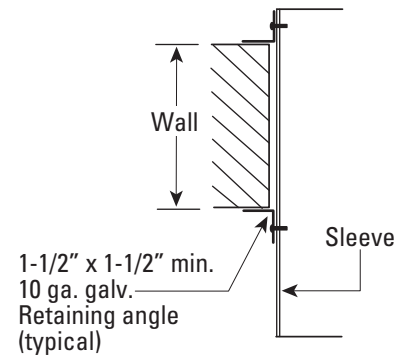

Detail D-D

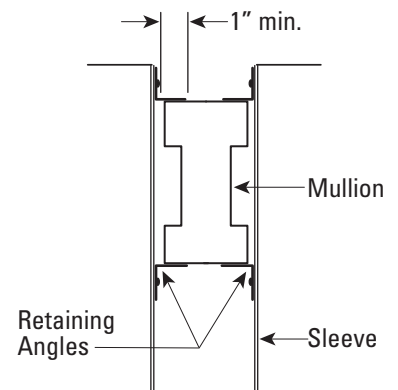

Detail E-E

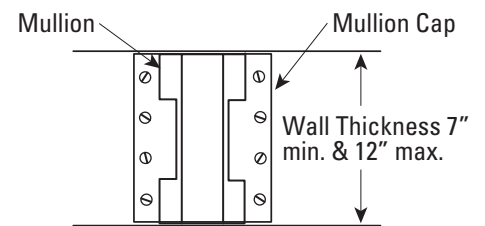

Detail F-F

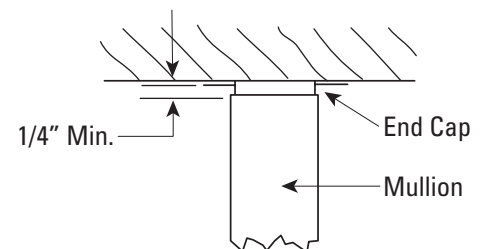

Detail G-G

FIGURE 1:

